

Flange a collarino a saldare di testa UNI 2280-67 PN 6

DIN 2631 ND6

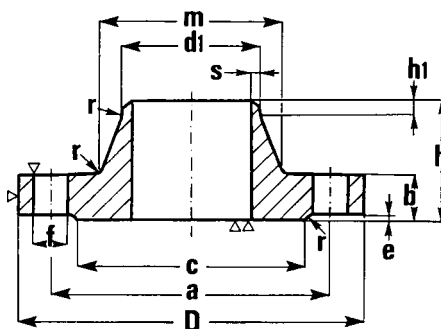

DN	Ø TUBO		d1		D	a	m		c	h	b	h1	e	r	s	f	VITI	N° fori	Kg.
	DIN	ISO	DIN	ISO			DIN	ISO											
10	13,5	17,2	14,5	18	75	50	22	26	35	28	12	6	2	4	2,3	11	M10	4	0,390
15	20	21,3	21	22,5	80	55	28	30	40	30	12	6	2	4	2,5	11	M10	4	0,450
20	25	26,9	26	28	90	65	35	38	50	32	14	6	2	4	2,5	11	M10	4	0,660
25	30	33,7	31	34,5	100	75	40	42	60	35	14	6	2	4	2,8	11	M10	4	0,820
32	38	42,4	39	43,5	120	90	50	55	70	35	14	6	2	6	3	14	M12	4	1,160
40	44,5	48,3	45,5	49,5	130	100	58	62	80	38	14	7	3	6	3	14	M12	4	1,380
50	57	60,3	58	61,5	140	110	70	74	90	38	14	8	3	6	3,5	14	M12	4	1,560
65	76,1		77		160	130	88		110	38	14	9	3	6	3,5	14	M12	4	1,950
80	88,9		90		190	150	102		128	42	16	10	3	8	3,7	18	M16	4	3,070
100	108	114,3	109	115,5	210	170	122	130	148	45	16	10	3	8	3,7	18	M16	4	3,560
125	133	139,7	134	141	240	200	148	155	178	48	18	10	3	8	4	18	M16	8	4,800
150	159	168,3	161	170,5	265	225	172	184	202	48	18	12	3	10	5	18	M16	8	5,520
200	219,1		221		320	280	236		258	55	20	15	3	10	5	18	M16	8	8,160
250	267	273	269	275	375	335	282	290	312	60	22	15	3	12	5,5	18	M16	12	11,100
300	323,9		326		440	395	342		365	62	22	15	4	12	6	22	M20	12	14,800
350	368	355,6	370	357,5	490	445	385		415	62	22	15	4	12	6,5	22	M20	12	19,500
400	419	406,4	421	408,5	540	495	438		465	65	22	15	4	12	7	22	M20	16	22,500
450	457,2		459		595	550	476		520	65	22	15	4	12	7,3	22	M20	16	25,000
500	508		510		645	600	538		570	68	24	15	4	12	7,3	22	M20	20	30,400
600	609,6		611,5		755	705	640		670	70	24	16	5	12	7,3	25	M22	20	38,000
700	711,2		715		860	810	740		775	70	24	16	5	12	9	25	M22	24	45,900
800	812,8		817		975	920	842		880	70	24	16	5	12	9	30	M27	24	55,000
900	914,4		918		1075	1020	942		980	70	26	16	5	12	9	30	M27	24	64,700
1000	1016		1020		1175	1120	1045		1080	70	26	16	5	16	9	30	M27	28	70,600
1200	1220		1224		1405	1340	1248		1295	90	28	20	5	16	9	33	M30	32	108,000
1400	1420		1424		1630	1560	1452		1510	90	32	20	5	16	9	36	M33	36	153,000
1600	1620		1624		1830	1760	1655		1710	90	34	20	5	16	11	36	M33	40	189,000
1800	1820		1824		2045	1970	1855		1920	100	36	20	5	16	11	39	M36x3	44	239,000
2000	2020		2024		2265	2180	2058		2125	110	38	25	5	16	12	42	M39x3	48	308,000

Flange a collarino a saldare di testa UNI 2281-67 PN10

DIN 2632 ND10

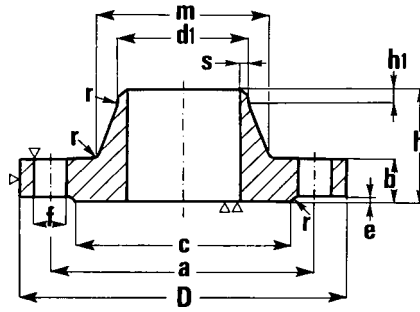

DN	Ø TUBO		d1		D	a	m		c	h	b	h1	e	r	s	f	VITI	N. FORI	Kg.
	DIN	ISO	DIN	ISO			DIN	ISO											
10	13,5	17,2	14,5	18	90	60	25	28	40	35	14	6	2	4	2,3	14	M12	4	0,650
15	20	21,3	21	22,5	95	65	30	32	45	35	14	6	2	4	2,5	14	M12	4	0,730
20	25	26,9	26	28	105	75	38	40	58	38	16	6	2	4	2,5	14	M12	4	1,030
25	30	33,7	31	34,5	115	85	42	45	68	38	16	6	2	4	2,8	14	M12	4	1,230
32	38	42,4	39	43,5	140	100	52	56	78	40	16	6	2	6	3	18	M16	4	1,800
40	44,5	48,3	45,5	49,5	150	110	60	64	88	42	16	7	3	6	3	18	M16	4	2,080
50	57	60,3	58	61,5	165	125	72	75	102	45	18	8	3	6	3,5	18	M16	4	2,780
65	76,1		77		185	145	90		122	45	18	10	3	6	3,5	18	M16	4	3,400
80	88,9		90		200	160	105		138	50	20	10	3	8	3,7	18	M16	4	4,200
100	108	114,3	109	115,5	220	180	125	131	158	52	20	12	3	8	3,7	18	M16	8	4,750
125	133	139,7	134	141	250	210	150	156	188	55	22	12	3	8	4	18	M16	8	6,450
150	159	168,3	161	170,5	285	240	175	184	212	55	22	12	3	10	5	22	M20	8	8,000
200	219,1		221		340	295	235		268	62	24	16	3	10	5	22	M20	8	11,400
250	267	273	269	275	395	350	285	292	320	68	26	16	3	12	5,5	22	M20	12	15,200
300	323,9		326		445	400	344		370	68	26	16	4	12	6	22	M20	12	18,000
350	368	355,6	370	357,5	505	460	385		430	68	26	16	4	12	6,4	22	M20	16	24,500
400	419	406,4	421	408,5	565	515	440		482	72	26	16	4	12	7	25	M22	16	30,200
450	457,2		459		615	565	478		532	72	26	16	4	12	7,3	25	M22	20	32,300
500	508		510		670	620	542		585	75	28	16	4	12	7,3	25	M22	20	40,400
600	609,6		611,5		780	725	642		685	80	28	18	5	12	7,3	30	M27	20	50,000
700	711,3		715		895	840	745		800	80	30	18	5	12	9	30	M27	24	66,400
800	812,8		817		1015	950	850		905	90	32	18	5	12	9	33	M30	24	89,300
900	914,4		918		1115	1050	950		1005	95	34	20	5	12	9	33	M30	28	104,000
1000	1016		1020		1230	1160	1052		1110	95	34	20	5	16	9	36	M33	28	121,000
1200	1220		1224		1455	1380	1255		1330	115	38	25	5	16	10	39	M36x3	32	180,000
1400	1420		1424		1675	1590	1460		1535	120	42	25	5	16	11	42	M39x3	36	248,000
1600	1620		1624		1915	1820	1665		1760	130	46	25	5	16	12	48	M45x3	40	352,000
1800	1820		1824		2115	2020	1868		1960	140	50	30	5	16	13	48	M45x3	44	433,000
2000	2020		2024		2325	2230	2072		2170	150	54	30	5	16	14	48	M45x3	48	543,000

Flange a collarino a saldare di testa UNI 2282-67 PN 16

DIN 2633 ND16

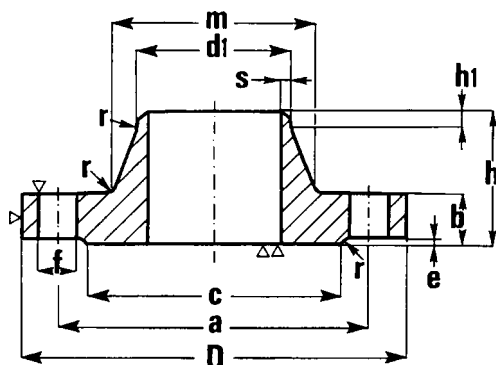

DN	Ø TUBO		d1		D	a	m		c	h	b	h1	e	r	s	f	VITI	N° fori	Kg
	DIN	ISO	DIN	ISO			DIN	ISO											
10	13,5	17,2	14,5	18	90	60	25	28	40	35	14	6	2	4	2,3	14	M12	4	0,650
15	20	21,3	21	22,5	95	65	30	32	45	35	14	6	2	4	2,5	14	M12	4	0,730
20	25	26,9	26	28	105	75	38	40	58	38	16	6	2	4	2,5	14	M12	4	1,030
25	30	33,7	31	34,5	115	85	42	45	68	38	16	6	2	4	2,8	14	M12	4	1,230
32	38	42,4	39	43,5	140	100	52	56	78	40	16	6	2	6	3	18	M16	4	1,800
40	44,5	48,3	45,5	49,5	150	110	60	64	88	42	16	7	3	6	3	18	M16	4	2,080
50	57	60,3	58	61,5	165	125	72	75	102	45	18	8	3	6	3,5	18	M16	4	2,780
65	76,1		77		185	145	90		122	45	18	10	3	6	3,5	18	M16	4	3,400
80	88,9		90		200	160	105		138	50	20	10	3	8	3,7	18	M16	8	4,200
100	108	114,3	109	115,5	220	180	125	131	158	52	20	12	3	8	3,7	18	M16	8	4,750
125	133	139,7	134	141	250	210	150	156	188	55	22	12	3	8	4	18	M16	8	6,450
150	159	168,3	161	170,5	285	240	175	184	212	55	22	12	3	10	5	22	M20	8	8,000
200	219,1		221		340	295	235		268	62	24	16	3	10	5	22	M20	12	11,100
250	267	273	269	275	405	355	285	292	320	70	26	16	3	12	5,5	25	M22	12	16,300
300	323,9		326		460	410	344		378	78	28	16	4	12	6	25	M22	12	21,800
350	368	355,6	370	357,5	520	470	390		438	82	30	16	4	12	6,4	25	M22	16	31,700
400	419	406,4	421	408,5	580	525	445		490	85	32	16	4	12	7	30	M27	16	38,300
450	457,2		459		640	585	485		550	85	32	16	4	12	7,3	30	M27	20	45,400
500	508		510		715	650	548		610	90	34	16	4	12	7,3	33	M30	20	61,100
600	609,6		611,5		840	770	652		725	95	36	18	5	12	7,3	36	M33	20	84,600
700	711,3		715		910	840	755		795	100	36	18	5	12	9	36	M33	24	87,400
800	812,8		817		1025	950	855		900	105	38	20	5	12	9	39	M36x3	24	109,000
900	914,4		918		1125	1050	955		1000	110	40	20	5	12	10	39	M36x3	28	129,000
1000	1016		1020		1255	1170	1058		1115	120	42	22	5	16	12	42	M39x3	28	175,000
1200	1220		1224		1485	1390	1262		1330	130	48	30	5	16	14	48	M45x3	32	257,000
1400	1420		1424		1685	1590	1465		1530	145	52	30	5	16	16	48	M45x3	36	337,000
1600	1620		1624		1930	1820	1668		1750	160	58	35	5	16	17	56	M52x3	40	481,000
1800	1820		1824		2130	2020	1870		1950	170	62	35	5	16	19	56	M52x3	44	591,000
2000	2020		2024		2345	2230	2072		2150	180	66	40	5	16	21	62	M56x4	48	727,000

Flange a collarino a saldare di testa UNI 2283-67 PN25

DIN 2634 ND25

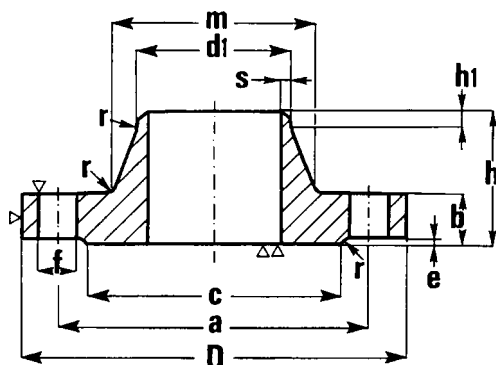

DN	Ø TUBO		d1		D	a	m		c	h	b	h1	e	r	s	f	VITI	N° FORI	Kg
	DIN	ISO	DIN	ISO			DIN	ISO											
10	13,5	17,2	14,5	18	90	60	25	28	40	35	16	6	2	4	2,3	14	M12	4	0,740
15	20	21,3	21	22,5	95	65	30	32	45	38	16	6	2	4	2,5	14	M12	4	0,830
20	25	26,9	26	28	105	75	38	40	58	40	18	6	2	4	2,5	14	M12	4	1,150
25	30	33,7	31	34,5	115	85	42	46	68	40	18	6	2	4	2,8	14	M12	4	1,380
32	38	42,4	39	43,5	140	100	52	56	78	42	18	6	2	6	3	18	M16	4	2,010
40	44,5	48,3	45,5	49,5	150	110	60	64	88	45	18	7	3	6	3	18	M16	4	2,330
50	57	60,3	58	61,5	165	125	72	75	102	48	20	8	3	6	3,5	18	M16	4	3,080
65	76,1		77		185	145	90		122	52	22	10	3	6	3,5	18	M16	8	3,950
80	88,9		90		200	160	105		138	58	24	12	3	8	3,7	18	M16	8	4,980
100	108	114,3	109	115,5	235	190	128	134	162	65	24	12	3	8	3,7	22	M20	8	6,700
125	133	139,7	134	141	270	220	155	162	188	68	26	12	3	8	4	25	M22	8	9,200
150	159	168,3	161	170,5	300	250	182	192	218	75	28	12	3	10	5	25	M22	8	12,000
200	219,1		221		360	310	244		278	80	30	16	3	10	5	25	M22	12	16,800
250	267	273	269	275	425	370	292	298	335	88	32	18	3	12	5,5	30	M27	12	23,300
300	323,9		326		485	430	352		390	92	34	18	4	12	6	30	M27	16	30,500
350	368	355,6	370	357,5	555	490	398		450	100	38	20	4	12	6,4	33	M30	16	47,600
400	419	406,4	421	408,5	620	550	452		505	110	40	20	4	12	7,3	36	M33	16	62,100
450	457,2		459		670	600	492		555	115	40	20	4	12	8	36	M33	20	67,800
500	508		510		730	660	558		615	125	44	20	4	12	8	36	M33	20	88,800
600	609,6		611,5		845	770	660		720	125	46	20	5	12	8	39	M36x3	20	114,000
700	711,2		715		960	875	760		820	125	46	20	5	12	10	42	M39x3	24	138,000
800	812,8		817		1085	990	865		930	135	50	22	5	12	11	48	M45x3	24	185,000
900	914,4		918		1185	1090	968		1030	145	54	24	5	12	12	48	M45x3	28	224,000
1000	1016		1020		1320	1210	1070		1140	155	58	24	5	16	13	56	M52x3	28	293,000

Flange a collarino a saldare di testa UNI 2284-67 PN 40

DIN 2635 ND40

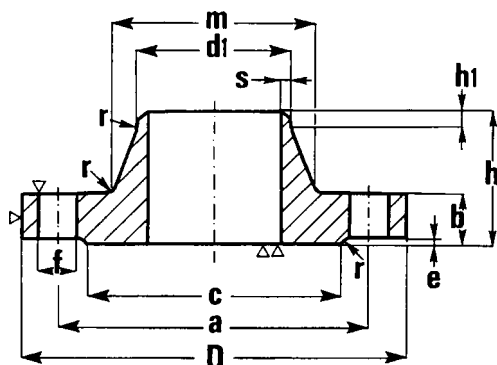

DN	Ø TUBO		d ₁		D	a	m		c	h	b	h ₁	e	r	s	f	VITI	N° FORI	Kg.
	DIN	ISO	DIN	ISO			DIN	ISO											
10	13,5	17,2	14,5	18	90	60	25	28	40	35	16	6	2	4	2,3	14	M12	4	0,740
15	20	21,3	21	22,5	95	65	30	32	45	38	16	6	2	4	2,5	14	M12	4	0,830
20	25	26,9	26	28	105	75	38	40	58	40	18	6	2	4	2,5	14	M12	4	1,150
25	30	33,7	31	34,5	115	85	42	46	68	40	18	6	2	4	2,8	14	M12	4	1,380
32	38	42,4	39	43,5	140	100	52	56	78	42	18	6	2	6	3	18	M16	4	2,010
40	44,5	48,3	45,5	49,5	150	110	60	64	88	45	18	7	3	6	3	18	M16	4	2,330
50	57	60,3	58	61,5	165	125	72	75	102	48	20	8	3	6	3,5	18	M16	4	3,080
65	76,1		77		185	145	90		122	52	22	10	3	6	3,5	18	M16	8	3,950
80	88,9		90		200	160	105		138	58	24	12	3	8	3,7	18	M16	8	4,980
100	108	114,3	109	115,5	235	190	128	134	162	65	24	12	3	8	3,7	22	M20	8	6,700
125	133	139,7	134	141	270	220	155	162	188	68	26	12	3	8	4	25	M22	8	9,200
150	159	168,3	161	170,5	300	250	182	192	218	75	28	12	3	10	5	25	M22	8	12,000
200	219,1		221		375	320	244		285	88	34	16	3	10	5,5	30	M27	12	20,800
250	267	273	269	275	450	385	298	306	345	105	38	18	3	12	6,5	33	M30	12	33,800
300	323,9		326		515	450	362		410	115	42	18	4	12	7,3	33	M30	16	47,400
350	368	355,6	370	357,5	580	510	408		465	125	46	20	4	12	8	36	M33	16	69,000
400	419	406,4	421	408,5	660	585	462		535	135	50	20	4	12	9	39	M36x3	16	86,500
450	457,2		459		685	610	500		560	135	50	20	4	12	9	39	M36x3	20	91,600
500	508		510		755	670	562		615	140	52	20	4	12	10	42	M39x3	20	117,000
600	609,6		611,5		890	795	666		735	145	54	20	5	12	18	48	M45x3	20	145,000
700	711,2		715		995	900	768		840	145	58	20	5	12	18	48	M45x3	24	190,000
800	812,8		817		1140	1030	875		960	150	60	22	5	12	20	56	M52x3	24	260,000
900	914,4		918		1250	1140	980		1070	155	64	24	5	12	22	56	M52x3	28	335,000
1000	1016		1020		1360	1250	1090		1180	165	68	24	5	16	25	56	M52x3	28	440,000

Flange a collarino a saldare di testa

UNI 2285-67 PN64 UNI 2286-67 PN100

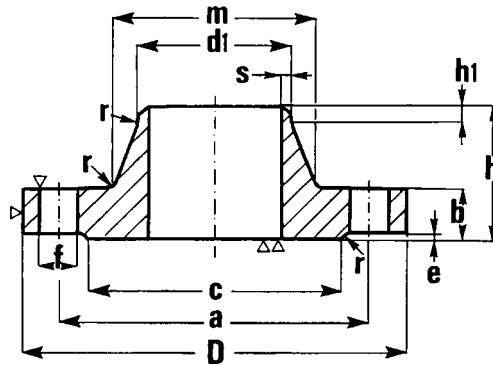

DN	Ø TUBO		d1		D	a	m		c	h	b	h1	e	r	s	f	VITI	N. FORI	Kg.
	DIN	ISO	DIN	ISO			DIN	ISO											

UNI 2285-67 PN64

DAL DN 10 AL DN 40 IMPIEGARE FLANGE PN 100 UNI 2286-67																			
50	57	60,3	58	61,5	180	135	78	82	95	62	26	10	3	6	3,5	22	M20	4	4,450
65	76,1		77		205	160	98		120	68	26	12	3	6	3,5	22	M20	8	5,500
80	88,9		90		215	170	112		130	72	28	12	3	8	3,7	22	M20	8	6,430
100	108	114,3	109	115,5	250	200	132	138	160	78	30	12	3	8	4	25	M22	8	9,050
125	133	139,7	134	141	295	240	162	168	185	88	34	12	3	8	5	30	M27	8	14,200
150	159	168,3	161	170,5	345	280	192	202	215	95	36	12	3	10	6	33	M30	8	20,800
200	219,1		221		415	345	256		270	110	42	16	3	10	7,3	36	M33	12	33,200
250	267	273	269	275	470	400	310	316	325	125	46	18	3	12	8	36	M33	12	46,000
300	323,9		326		530	460	372		375	140	52	18	4	12	9,8	36	M33	16	63,900
350	368	355,6	370	357,5	600	525	420		435	150	56	20	4	12	11	39	M36x3	16	93,000
400	419	406,4	421	408,5	670	585	475		485	160	60	20	4	12	12	42	M39x3	16	122,000

UNI 2286-67 PN100

10	13,5	17,2	14,5	18	100	70	28	32	40	45	20	6	2	4	2,3	14	M12	4	1,080
15	20	21,3	21	22,5	105	75	32	34	45	45	20	6	2	4	2,5	14	M12	4	1,190
20	25	26,9	26	28	130	90	42	44	58	52	22	8	2	4	2,8	18	M16	4	2,020
25	30	33,7	31	34,5	140	100	48	52	65	58	24	8	2	4	2,8	18	M16	4	2,600
32	38	42,4	39	43,5	155	110	58	62	75	60	24	8	2	6	3	22	M20	4	3,120
40	44,5	48,3	45,5	49,5	170	125	65	70	85	62	26	10	3	6	3,5	22	M20	4	3,990
50	57	60,3	58	61,5	195	145	86	90	95	68	28	10	3	6	4	25	M22	4	5,750
65	76,1		77		220	170	108		120	76	30	12	3	6	4,5	25	M22	8	7,570
80	88,9		90		230	180	120		130	78	32	12	3	8	5	25	M22	8	8,720
100	108	114,3	109	115,5	265	210	145	150	160	90	36	12	3	8	6	30	M27	8	12,900
125	133	139,7	134	141	315	250	180		185	105	40	12	3	8	6,8	33	M30	8	20,700
150	159	168,3	161	170,5	355	290	210		215	115	44	12	3	10	7	33	M30	12	27,400
200	219,1		221		430	360	278		270	130	52	16	3	10	9,8	36	M33	12	48,700
250	267	273	269	275	505	430	340		325	157	60	18	3	12	12	39	M36	12	78,800
300	323,9		326		585	500	400		375	170	68	18	4	12	13,5	42	M39x3	16	114,000
350	368	355,6	370	357,5	655	560	460		435	189	74	20	4	12	15,2	48	M45x3	16	163,000
400	419	406,4	421	408,5	715	620	520		485	200	80	20	4	12	18	48	M45x3	16	220,000